

Spec Sheet - HICS62E Chef'sCombi 6 GN Electric



Technical characteristics

CODE	
Article code	HICS62E
Technical code	HICS62E

DIMENSIONS (H x W x A)	
Exterior (total)	898 x 1042 x 1043 mm
Exterior (body)	754 x 1042 x 976 mm
Maximum working height*	1380 / 1558 mm
Minimum working height *	965 / 1143 mm
Oven height + base*	1589 / 1767 mm

* Depending on the height of the HOBART base used as an accessory

CAPACITIES	
Number of seats per day	200
GN 2/1 plates (650 x 530mm)	6
Max depth of bins	65 mm
Spacing between floors	83 mm
Maximum load per level	10 kg
Total maximum load	60 kg

WEIGHT (gross / net)	190 kg / 170 kg
----------------------	-----------------

PACKING	
Height x Width x Projection	1091 x 1090 x 1090 mm

MINIMUM DISTANCES / WALLS			
	LEFT	Back	RIGHT
Minimum deviation	50 mm	0 mm	50 mm
Standard	500 mm	0 mm	50 mm
Heat sources	350 mm	0 mm	50 mm

AIR EXHAUST AND THERMAL LOAD	
Latent thermal load	3942 W
Sensible heat emission	2628 W
Acoustic emission	< 70 dB (A)

CONSTRUCTION	
Muffle and Bodywork	Stainless Steel 18-10

DEVICE TYPE	Table top
-------------	-----------

CONNECTION SPECIFICS DATA	
LAN data interface	RJ45
WiFi data interface	IEEE 802.11 ac/a/b/g/n

ELECTRICITY	
Three phase 400V+E+N	
I. Max	34,2 kW
Total power	21,9 kW
“Steam” power	17,5 kW
“Pulsed air” power	21,6 kW
Necessary protection	35A curve C or B circuit breaker and 30mA AC type differential circuit breaker

COLD FOOD WATER	
Pressure (Min / Max)	150/600 kPa (1.5 bar / 6 bar)
Max cold water temperature	23°C
Nature	Filtered at 131 µm
Water quality	Chloride Cl ⁻ : ≤ 150 mg/l (150ppm) Free Chlorine Cl ₂ : ≤ 0.2 mg/l (0.2ppm) 6.5 ≤ PH ≤ 9
Conductivity	≥ 50 µS/cm
Connection	20/27 thread
Max. instantaneous consumption	12.7 l/min

Provide a shut-off valve nearby.

SOFT WATER	
Pressure (Min / Max)	150/600 kPa (1.5 bar / 6 bar)
Max softened water temperature	23°C
Nature	Filtered at 131 µm
Hardness	TH 6 to 10°fH (60 to 100 ppm)
Water quality	Chloride Cl ⁻ : ≤ 150 mg/l (150ppm) Free Chlorine Cl ₂ : ≤ 0.2 mg/l (0.2ppm) 6.5 ≤ PH ≤ 9
Conductivity	≥ 50 µS/cm
Connection	20/27 thread
Max. instantaneous consumption	7.7 l/min

Provide a shut-off valve nearby.

DRAIN	
Connection	Horizontal outlet Smooth tube Ø 40mm





The water discharged can be condensates at high temperatures, use materials adapted to these temperatures. It is imperative to have a siphon between the device and the drain network to prevent odors from rising.

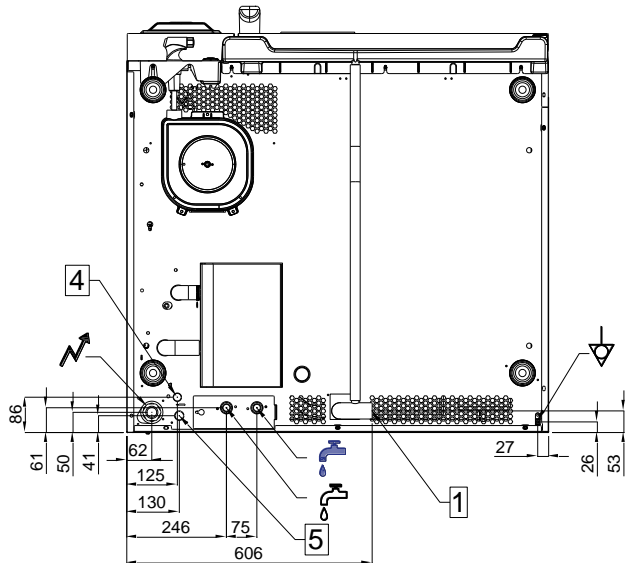
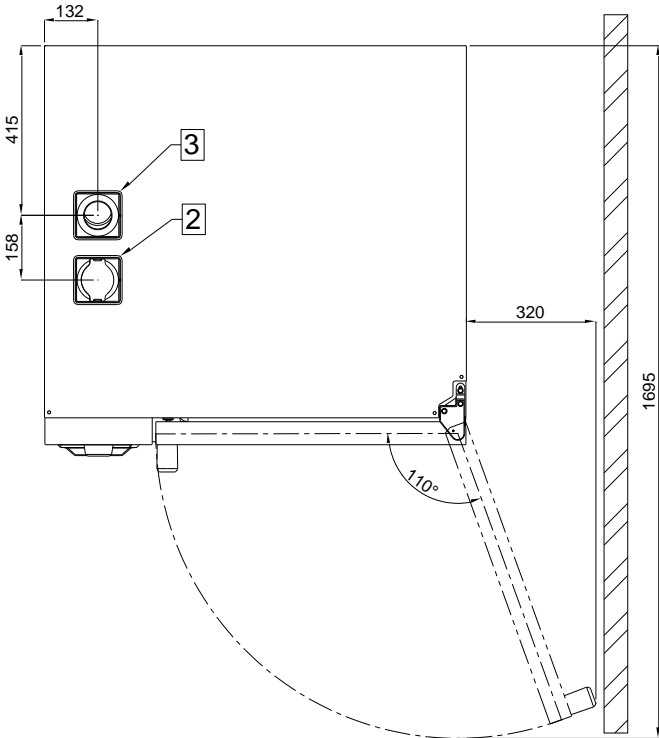
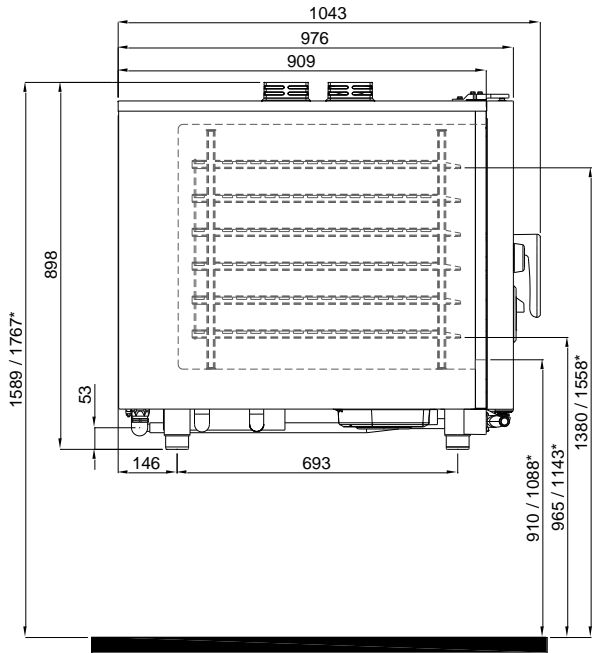
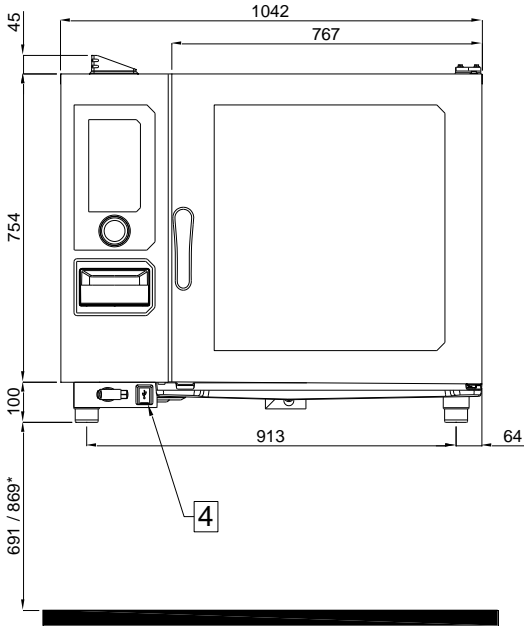

Technical drawing



* Depending on the height of the HOBART base used as an accessory

-  **ELECTRICAL connection**
Electric inlet at 260 mm from the support / 950-1129* from the floor
(Allow a cable with 1.5m of slack)
-  **COLD WATER food**
Water inlet at 80 mm from the support / 771-949* from the floor
-  **SOFT WATER**
Water inlet at 80 mm from the support / 771-949* from the floor
-  **ÉQUIPOTENTIAL BONDING**

- ① **DRAIN**
Drain outlet at 53 mm from the support / 744-922* from the floor
- ② **FLAPPER FIREPLACE**
Stainless steel tube diameter 70 mm
- ③ **EVACUATION OF EXCESS VAPORS**
Stainless steel tube diameter 70 mm
- ④ **ETHERNET PORT**
- ⑤ **ENERGY SAVING OPTION**